

| | | |
|---|---|------------------------------------|
|  | Title: YALE OFFICE OF FACILITIES PROCEDURE MANUAL Chapter: 01 - Yale Design Standard Division: Electrical Standards | Section: 26 10 04 Unit Substations |
| | | Date: 8/1/17 |
| | | Author: Office of Facilities |
| CC: Project Folder | | |

Change History

| Date | Description of Change | Pages / Sections Modified | Change Approver Initials |
|-----------------|---|---|--------------------------|
| <u>10/15/20</u> | <u>Updated section C.4.L, current transformer ratios.</u> | <u>C.4.L</u> | <u>JR</u> |
| 8/1/17 | Updated section for System Design and Performance Requirements; minor corrections in section for Manufacturers; Accessories or Special Features | 5>6 – C. 4 l. through n. 8>9 – F; H #7 & #9 | SO |
| 6/15/16 | Updated division section from 16361-U to 26 10 04, removed references to other section numbers | - | mgl44 |
| 11/21/14 | Amend text to refer to standard 16950 Electric Utility Meter; removed meter specific details and re-sequence subparagraphs. | 43 - 16361-U; C.#4.l &l. 1. (System Design and Performance Requirements) | SO |
| 11/21/14 | Add paragraph # 11; Amend text in paragraph #8, all for clarity. | 47>48 – 16361-U; H. #8 & #11 | SO |
| 10/17/14 | Amend text in section C at various sub-paragraphs to clarify existing conditions, intent and requirements. | 41>45 - 16361-U; C. #2.b & 2.g, #3.d & 3.e, #4.c , 4.k , 4.l.2), 4.l.3), 4.m. & 4.n. (System Design and Performance Requirements) | SO |
| 10/17/14 | Add text to paragraph #2 subset Shop Drawings Information, item c.to clarify nameplate data. | 45 - 16361-U; D. #2.c (Submittals) | SO |
| 10/17/14 | Add comment to item #3. | 46 - 16361-U, F .#3 (Manufacturers) | SO |
| 10/17/14 | Add new paragraphs #7, #8., #9 & #10 under 'Unit substation transformer standard features' section. | 47>48 - 16361-U; H. (Accessories or Special Features) | SO |
| 10/17/14 | Amend text to paragraph #1 + Add text to paragraph #3. | 48- 16361-U; K (Installation Guidelines) | SO |

A. Summary

This section contains design criteria for secondary unit substation which consisting of primary selector switches with fuses, cast coil copper wound substation transformers, and secondary switchgear and main protective devices.

B. References

The following industry standards, codes, and guidelines describe how the overall system should be designed:

1. ANSI C37.121, 1989 – Secondary Unit Substations
2. ANSI C37.13 – Low-voltage power circuit breakers

| | | |
|---|--|------------------------------------|
|  | <p>Title: YALE OFFICE OF FACILITIES PROCEDURE MANUAL Chapter: 01 - Yale Design Standard Division: Electrical Standards</p> | Section: 26 10 04 Unit Substations |
| | | Date: 8/1/17 |
| | | Author: Office of Facilities |
| CC: Project Folder | | |

3. ANSI C37.17 – Trip devices
4. ANSI C37.20 – Switchgear assemblies

| | | |
|---|---|------------------------------------|
|  | Title: YALE OFFICE OF FACILITIES PROCEDURE MANUAL Chapter: 01 - Yale Design Standard Division: Electrical Standards | Section: 26 10 04 Unit Substations |
| | | Date: 8/1/17 |
| | | Author: Office of Facilities |
| CC: Project Folder | | |

5. ANSI C39.1 – Meters
6. ANSI C62.1 – Surge Arresters
7. NEMA ST 20, 1997 and IEEE C.57.12.01 – dry-type, cast coil, 2-winding, substation transformer for indoor application.
8. UL 486A, UL 486B and UL 1558
9. NETA Acceptance Test Specifications (ATS)

C. System Design and Performance Requirements

Equipment service conditions shall meet temperature range of 0 to 40 degree C and humidity range of 5 to 95 percent, non-condensing.

1. The system shall consist of one duplex load interrupter switches with a cast coil copper wounded transformer with a 480 V switchgear. The switchgear shall contain main drawout electrical operated circuit breaker.
2. Alternate or Normal Single Ended Primary/Incoming Section Equipment
 - a. The primary of the system shall be two load interrupter switches for normal power and one switch (with space provisions for a second switch) for the alternate power system with common fuse that will allow the connection to the transformer to one of two incoming lines mounted inside dead-front metal enclosed compartment with a view window and with a close couple connection to the transformer section. Each of the primary switch that receives the radial feeders shall have 18 Kv or 5 Kv station class lightning / surge arresters.
 - b. Each duplex interrupter switch shall have two sets of synchronized sources incoming lines. These switches are provided for manual primary close transition throwover. Each switch section shall have a strip space heaters.
 - c. Terminals shall be compression-type for use with low smoke, zero halogen type and size 500 MCM cables.
 - d. Maximum design voltage shall be 5 Kv with Basic Impulse Level 60 kV and continuous current rating of 600A for 4160 v system.
 - e. Maximum design voltage shall be 15 Kv with basic impulse level 95 Kv and continuous current rating of 600A for 13.8 Kv system.

| | | |
|---|---|------------------------------------|
|  | Title: YALE OFFICE OF FACILITIES PROCEDURE MANUAL Chapter: 01 - Yale Design Standard Division: Electrical Standards | Section: 26 10 04 Unit Substations |
| | | Date: 8/1/17 |
| | | Author: Office of Facilities |
| CC: Project Folder | | |

- f. One set of three power fuses shall be mounted in separate compartment within switch cabinet. Fuses shall be accessible through a hinged door, mechanically interlocked with interrupter switch such that entry may only be accomplished by de-energizing the switch.
- g. Interrupter enclosure shall be rated for the environment.
- h. The interrupter switches shall have Kirk key interlock for locking out system for maintenance purpose.
- i. Switches shall be rear accessible.
- j. Connections between incoming switches and transformer shall be made with Buss or with shielded 15Kv cable with a low smoke zero Halogen jacket.
- k. A nameplate shall be provided that is engraved to indicate the fuse type and size that is installed.
- l. All emergency / alternate electrical equipment shall be separated from the normal electrical equipment by a 2 hr rated wall. Each system shall have separate rooms without exception.

3. Transformer Section Equipment

- a. Substation transformer shall be dry-type, cast coil, copper wound, 2-winding, air cooled with forced air Class AA/FA rating. Core and coil assembly shall be enclosed in a ventilated steel housing for indoor application.
- b. Transformer connection shall be delta- wye with 5 kV primary, basic Impulse Level 60 kV and 480 Y/277 volts secondary for 4160 V system.
- c. Transformer connection shall be delta-Wye with 15 Kv primary, basic impulse level 95 Kv and 480 Y/277 volts secondary for 13.8 Kv system.
- d. The cast coil transformer shall have 185 degree C insulation with 80 degree C rise over 40 degree C.
- e. Cast coil transformer shall include 120/240 VAC cooling fan to provide 33% additional capacity with winding temperature monitor and alarm. Transformer shall have a separate ground to building ground bus with # 4/0 Awg copper wire. The transformer alarm panel shall be fed from the CPT in the switchgear section.

| | | |
|---|---|------------------------------------|
|  | Title: YALE OFFICE OF FACILITIES PROCEDURE MANUAL Chapter: 01 - Yale Design Standard Division: Electrical Standards | Section: 26 10 04 Unit Substations |
| | | Date: 8/1/17 |
| | | Author: Office of Facilities |
| CC: Project Folder | | |

- f. The unit substation shall be grounded in three (3) locations (one on the transformer, one on the main interrupter switches and one on the 480 V switchgear), forming three (3) separate ground paths to the building ground bus. All ground conductors shall not be smaller than size #4/0 Awg copper wire. Insure the ground resistance at the substation is no more than 5 ohms by adding more number of ground conductors, and/or ground rods for building grounding system.
- g. Provide isolation pads to isolate core and coil assembly from casing.
- h. Provide four 2-1/2 percent full capacity taps, two above and two below rated nominal voltage.
- i. Dry type transformer sound level shall not exceed the maximum specified by NEMA TR-1 as shown below and latest D.O.E. Standards.

- 1. 301 – 500 kVA < 60 dB
- 2. 501 – 700 kVA < 62 dB
- 3. 701 – 1000 kVA < 64 dB
- 4. 1500 – 2000 kVA < 65 dB

4. Secondary Low Voltage Switchgear Section Equipment

- a. The switchgear shall be directly connected to the adjacent transformer section and include main circuit breaker with surge protection device. Surge protection shall be mounted directly to the bus in main protection devices section in accordance with the requirement of Section Transient Voltage Surge Suppression.
- b. Provide line and load terminals accessible from the front only and they are suitable for conductors termination.
- c. Main circuit breaker shall be electrically operated and true draw-out mounted, RMS sensing electronic trip with LSIG functions, insulated case, two-step stored energy type circuit breaker. Branch circuit breakers can be molded case with LSI settings.
- d. Breaker shall have shunt trip wired out to terminal block. This wiring shall be used for the fire alarm panel button to trip the main breaker in this switchgear.
- e. Bus connections shall be bolted, and accessible from front for easy maintenance.

| | | |
|---|---|------------------------------------|
|  | Title: YALE OFFICE OF FACILITIES PROCEDURE MANUAL Chapter: 01 - Yale Design Standard Division: Electrical Standards | Section: 26 10 04 Unit Substations |
| | | Date: 8/1/17 |
| | | Author: Office of Facilities |
| CC: Project Folder | | |

- f. Bus or flexible bus link shall be copper and be sized in accordance with NEMA PB 2 Standard.
- g. Sections shall be aligned at front only.
- h. Provide fully equipped future space provisions with bussing and bus connections.
- i. Substation design shall be suitable for the environment.
- j. Unit substation shall be equipped with under voltage relays per Figure 1-1.
- k. If switchgear is separated from transformer, the use of conduit and wire shall not be used. Only bus duct shall be acceptable connections.
- l. Each 480 V low voltage switchgear section shall be equipped with a Schneider PowerLogic 5560 meter which shall be tied into the Yale data collection and storage system. See Yale University Design Standard 33 62 00 'Hydronic, Steam and Electrical Energy Metering' and separate Detail for the complete specification on the PowerLogic Meter and the electrical and communications components necessary to have a complete and functional system.

1. The current transformers for PowerLogic meters, size and quantities are indicated on the drawings. The current transformers with current ratio shall be the class as listed below. The burden for metering CTs shall be in accordance with Table 10 of IEEE C57.13, and the burden for relaying CTs shall be in accordance with Table 13 of IEEE C57.13. Current transformer accuracy shall be 0.3% for metering and relaying functions. Accuracy classes of 0.6% and 1.2% will be accepted for instruments with higher burden but must still be in accordance with Clause 5 of IEEE C57.13.

100/5 ratio: shall be class 10 (B-0.1) current transformer.

200/5 and 400/5 ratio: shall be class 20 (B-0.2) current transformer

500/5 and 600/5 ratio: shall be a class 50 (B-0.5) current transformer.

800/5, 1000/5, 1200/5 and 1600/5 ratio: shall be a class 100 (B-1) current transformer.

2000/5 and higher ratio: shall be a class 200 (B-2) current transformer.

| | | |
|---|---|------------------------------------|
|  | Title: YALE OFFICE OF FACILITIES PROCEDURE MANUAL Chapter: 01 - Yale Design Standard Division: Electrical Standards | Section: 26 10 04 Unit Substations |
| | | Date: 8/1/17 |
| | | Author: Office of Facilities |
| CC: Project Folder | | |

When an Arc Flash system is to be installed, the CTs used for that system shall be as the class 100 series CTs. These CTs shall be a class 100 current transformer using an ITI model #115, #306, #386, #388 or #680.

2. All wiring for CTs shall be #10 AWG stranded SIS type wire.
 3. All PowerLogic meter CT wiring shall be wired to shorting blocks before being wired to the ABB test block. All wiring from the test block to the meter shall be tagged per the vendor supplied interconnection drawings. Test block shall be ABB style FT-1 and Cat # 129A514G01 with clear covers.
 4. Contractor shall install a raceway for data cable to connect this meter with the Yale data collection system via a connection point within the building to be specified by Yale.
- m. Switch gear shall have an engraved name plate mounted below the meter indicating the CT ratio associated with the PowerLogic meter.

D. Submittals

1. Designer Submittals

- a. The protective devices short circuit and over current protection coordination study shall accompany unit substation submittals and the study shall certify all its components and the substation meets or exceeds the electrical system requirement. Study shall include all 480V feeder breakers in switchgear.

2. Construction Documents

Submit the following construction documents:

Product Data

- a. Submit manufacturer's catalog data for secondary unit substations and components including construction details and component and device specifications.

Shop Drawings Information

Submit project-specific shop drawings including the following:

- a. Front and side views of enclosures with overall dimension shown.

| | | |
|---|---|------------------------------------|
|  | Title: YALE OFFICE OF FACILITIES PROCEDURE MANUAL Chapter: 01 - Yale Design Standard Division: Electrical Standards | Section: 26 10 04 Unit Substations |
| | | Date: 8/1/17 |
| | | Author: Office of Facilities |
| CC: Project Folder | | |

- b. Conduit entrance locations and requirements
- c. Nameplate legends, including fuse type & size and the CT ratio associated with each PowerLogic Meter.
- d. Size and number of bus bars per phase, neutral, and ground.
- e. Primary selector device, transformer, secondary main-tie-main devices, instrument and metering details.
- f. Instruction for handling and installation of the unit substation.
- g. Electrical characteristics including voltage, frame size and trip ratings, withstand ratings, and time-current curves of equipment and components.

Certified Test Reports

- a. Provide factory transformer certified loss evaluation report.
- b. Provide field test reports and certify that the system is in compliance with test parameters.

Field Measurements

- a. Make necessary field measurements and provide equipment layout diagram to confirm that equipment shall fit in allocated space in full compliance with minimum required clearances specified in National Electrical Code.

Operations and Maintenance Data

- a. Provide overcurrent protective device adjusting and testing instructions.
- b. O & M Manuals shall include bus tightening intervals and procedures, and overcurrent protective device maintenance procedures.

E. Product Standards

Products shall conform to the following standards:

1. ANSI C57.1201
2. NEMA PB-2, 1995
3. Latest Codes and Standards
4. Latest D.O.E. Efficiency on Transformers

F. Manufacturers

| | | |
|---|---|------------------------------------|
|  | Title: YALE OFFICE OF FACILITIES PROCEDURE MANUAL Chapter: 01 - Yale Design Standard Division: Electrical Standards | Section: 26 10 04 Unit Substations |
| | | Date: 8/1/17 |
| | | Author: Office of Facilities |
| CC: Project Folder | | |

Subject to compliance with the design requirements, provide unit substation by one of the following manufacturers:

1. Square D
2. Cutler-Hammer/Eaton (Preferred)
3. ABB

G. Equipment

1. Power fuses shall be provided by Bussmann E-rated, GE Type EJ, or Shawmut Type CL-14.

H. Accessories or Special Features

Unit substation transformer standard features:

1. Stainless steel diagrammatic nameplate mounted on transformer enclosure.
2. Provide provisions for lifting and jacking unit into place.
3. Base suitable for rolling and skidding parallel to centerline.
4. Equip 120 VAC space heaters with thermostat.
5. Transformer high temperature monitor with local audible and visual alarm and contacts for remote alarm.
6. Each substation shall have a trolley lifting mechanism for the removal of circuit breakers.
7. Each substation shall be supplied with a NEMA 12 remote control panel. This panel shall contain red and green LED lights indicating the main breaker position. This panel shall also have a breaker control switch that will open and close the main breaker. There shall be a terminal block in this panel to be used for the wiring from this panel to the switchgear. Vendor drawings shall show this wiring so the contractor knows where the wiring for this panel is terminated in the switchgear. The electrical contractor shall mount this panel away from the switchgear on a wall or column so that it is not within the arc flash zone, but is in view of the front of the switchgear.
8. Switchgear shall contain an ABB arc flash fiber optic system. Switchgear shall be installed with relays and control wiring at the factory with the arc flash hardware. An ABB certified installer shall install the fiber optic wire at the job site after the major wire and cables have been installed. The bus shall have as a minimum two

| | | |
|---|---|------------------------------------|
|  | Title: YALE OFFICE OF FACILITIES PROCEDURE MANUAL Chapter: 01 - Yale Design Standard Division: Electrical Standards | Section: 26 10 04 Unit Substations |
| | | Date: 8/1/17 |
| | | Author: Office of Facilities |
| CC: Project Folder | | |

(2) fiber loops. The fiber run shall start from and include the transformer and run the length of the switchgear. This system shall have a full functional test before the electrical switchgear is put into service. Switchgear shall have one (1) REA 101 relay with associated hard wire and cables to have a fully functional and operating protection system.

9. Switchgear shall have one (1) set of CTs on the incoming line side of the main breaker. CTs shall be a minimum of Class 100 rating. Each CT shall be wired to shorting block and test block before being wired to REA 101 relay. System shall have test blocks so that all arc flash components can be removed without having to power down the substation. For approved PowerLogic Meter CTs see the section C.4.k.2. in this spec,. All test blocks shall be ABB type FT with clear covers. All REA 101 relays shall be supplied with clear covers so that accidental contact with the switches is not possible.
10. Arc flash shall operate as follows: When there is an arc flash and a high current the main circuit breaker shall trip. The tripping of the main breaker will be directly connected to the REA 101 relay. No interposing relays shall be used.
11. The substation shall have a two-position selector switch for Maintenance Mode. This switch will toggle between the “ENABLED” and “DISABLED” positions. A white LED will accompany the “DISABLED” position and a blue LED will accompany the “ENABLED” position. The white LED will be lit when the switch is in either position. The blue LED will light when the switch is in “ENABLED” mode. This switch will be tied into the main breaker so that when in “ENABLED” mode the pick-up value of the main breaker will be reduced to a setting that is three settings lower than normal. This is to reduce arc flash hazard and protect personnel.

I. Extra Materials

1. One spare set of three 15 kV or 5 Kv power fuses shall be required.

J. Special Requirements

1. Frame and cover printed operating instructions for unit substations, including key interlocking, control sequences, and emergency procedures, with clear acrylic plastic. Insert instructions in a fabricated frame of finished wood or metal and mount on front of unit substation.

K. Installation Guidelines

1. Install unit substations on 4 inches high concrete housekeeping pad that is both

| | | |
|---|---|------------------------------------|
|  | Title: YALE OFFICE OF FACILITIES PROCEDURE MANUAL Chapter: 01 - Yale Design Standard Division: Electrical Standards | Section: 26 10 04 Unit Substations |
| | | Date: 8/1/17 |
| | | Author: Office of Facilities |
| CC: Project Folder | | |

two (2) inches wider and longer than substation widest and longest section.

2. Tack weld or bolt substation support footings to channel-iron sills embedded in the concrete pad. Install sills level and grout flush with pad surface.
3. Ground all metal parts of the unit substation to main electrical ground bus at three (3) locations, at: each set of switches, the transformer section and the switchgear section. The section with the transformer shall have a VIB-X Pad between the transformer and the concrete pad for insulation and vibration damping.
4. Tighten all electrical connectors and terminals according to manufacturer's published torque values or as specified in UL 486A and UL 486B.
5. Remove temporary lifting eyes, channels, brackets, and temporary blocking of moving parts from substation units and components.
6. Unit substation shall be accessible front and rear.

L. Field Quality Control

1. Field Quality Control Testing
 - a. Engage a factory-authorized service representative to supervise the field assembly of components, connections, preliminary testing, controls and safeties adjustment. Replace damaged and malfunctioning components and provide service result report in writing.
 - b. Owner will engage a qualified independent testing agency or an approved manufacturer's service organization to perform specific acceptance testing.
 - c. Perform visual and mechanical inspection and electrical tests stated in NETA ATS or submit equivalent manufacturer's startup procedures.
 - d. Perform load interrupter switchgear testing in accordance with NETA ATS, Section 7.5 Standards or approved equivalent manufacturer's startup procedures.
 - e. Perform air transformer testing in accordance with NETA ATS, Section 7.2 Standards or approved equivalent manufacturer's startup procedures.
 - f. Perform low voltage switchgear testing in accordance with NETA ATS, Section 7.2 Standards or approved equivalent manufacturer's startup procedures.
 - g. After the electrical testing is complete and the substation has been

| | | |
|---|---|------------------------------------|
|  | Title: YALE OFFICE OF FACILITIES PROCEDURE MANUAL Chapter: 01 - Yale Design Standard Division: Electrical Standards | Section: 26 10 04 Unit Substations |
| | | Date: 8/1/17 |
| | | Author: Office of Facilities |
| CC: Project Folder | | |

energized, demonstrate product and control capability in compliance with requirements.

- h. Remove and replace malfunctioning components with new units and retest.
- i. Provide certified reports that the system is in compliance with test parameters.
- j. All equipment shall be vacuumed and cleaned prior to energization.

2. Commissioning

If this portion of the project includes commissioning, verify that insertions in the project specifications have been made that refer to the commissioning procedures in the commissioning specification section. Verify that the systems and equipment identified in this section of the standards, and listed in the project specifications, do not conflict with commissioning procedures for testing and training.

3. Monitoring

After Substantial Completion, when requested by owner, but no more than 6 months after Final Acceptance, commissioning agent will perform the following voltage monitoring and adjusting:

- a. During a period of normal load cycles as evaluated by owner, perform 7 days of 3-phase voltage recording at the low voltage switchgear outgoing section of the unit substation. Use voltmeters with calibration traceable to National Institute of Standards and Technology standards and with a chart speed of no less than 1 inch (25 mm) per hour. Voltage unbalance greater than 1 percent between phases or deviation of any phase voltage from the nominal value by more than plus or minus 5 percent during the test period is unacceptable.
- b. If test results are unacceptable, take the following corrective actions, as appropriate:
 - Adjust transformer taps
 - Rebalance loads
 - Send a written request to the electrical utility for voltage adjustment
- c. Repeat monitoring, after corrective action has been performed, until satisfactory results are obtained.

| | | |
|---|---|------------------------------------|
|  | Title: YALE OFFICE OF FACILITIES PROCEDURE MANUAL Chapter: 01 - Yale Design Standard Division: Electrical Standards | Section: 26 10 04 Unit Substations |
| | | Date: 8/1/17 |
| | | Author: Office of Facilities |
| CC: Project Folder | | |

- d. Provide a written report describing voltage monitoring performance and corrective action taken.

M. Cleaning and Adjusting

- 1. Clean and vacuum interior of separate enclosures to remove construction debris, dirt, and shipping material. Wipe all buses and terminals to remove dust with water or alcohol damped cloth.

N. Startup and Training

Engage a factory-authorized service representative to train owner’s maintenance personnel as specified below:

- 1. Train owner’s maintenance personnel on procedures and schedules related to startup and shutdown, troubleshooting, servicing, and preventive maintenance.
- 2. Review data in the maintenance manuals. Refer to Division1, Section 01730 Project Execution and Closeout.
- 3. Review data in the maintenance manuals. Refer to Division1, Section 01782 Operation and Maintenance Data.
- 4. Schedule training with owner, through Architect, with at least 7 days’ advance notice.

“Continued on Following Page”



Title: YALE OFFICE OF FACILITIES PROCEDURE MANUAL
Chapter: 01 - Yale Design Standard
Division: Electrical Standards

Section: 26 10 04 Unit
Substations

Date: 8/1/17

Author: Office of Facilities

CC: Project Folder

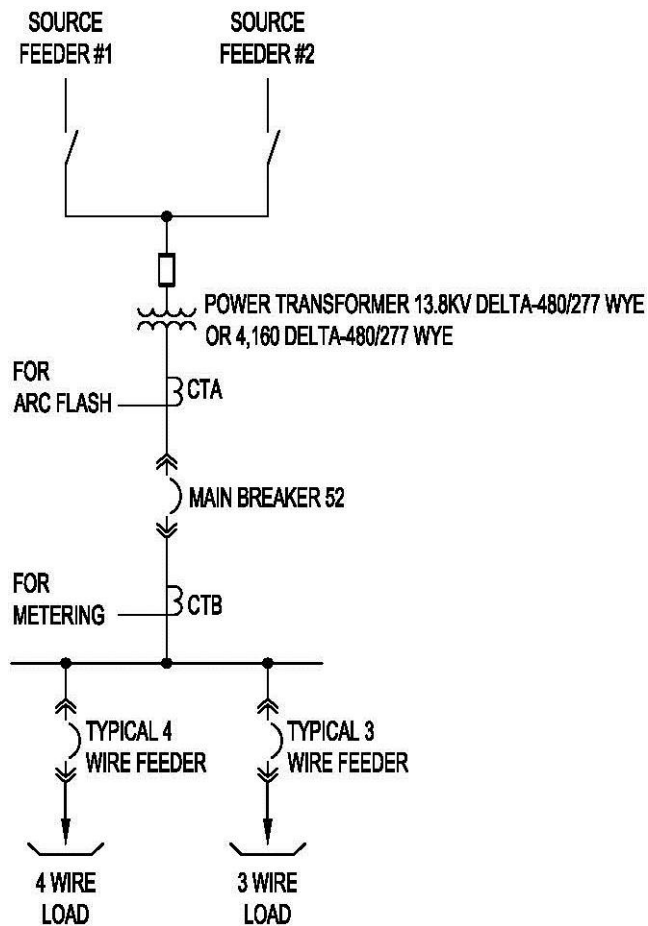

| | | |
|---|--|------------------------------------|
|  | <p>Title: YALE OFFICE OF FACILITIES PROCEDURE MANUAL Chapter: 01 - Yale Design Standard Division: Electrical Standards</p> | Section: 26 10 04 Unit Substations |
| | | Date: 8/1/17 |
| | | Author: Office of Facilities |
| CC: Project Folder | | |

End of Section